

# Polar<sup>®</sup> Focus

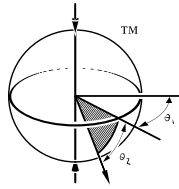

Audio Rigging Products

## V-DOSC Spreader VB-42-2000

The V-DOSC Spreader is designed as an accessory for the standard V-DOSC grid. Initially developed for use in theaters where only one audio rigging point is available per side, it also provides steep up tilt (up to 20°) to help cover high balconies. L'Acoustics and Cox Audio have approved the use of the spreader for 20° up tilt with a maximum of six enclosures.

Using two V-DOSC Spreaders to support a single V-DOSC grid allows side by side rigging points, instead of requiring conventional fore and aft V-DOSC rigging points.

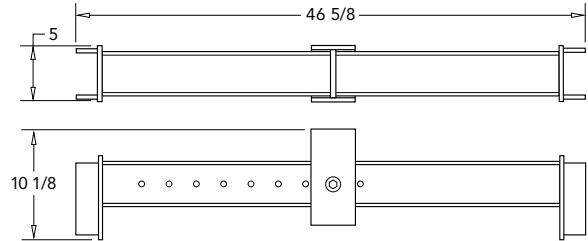

weight: 59 lbs.

primary material: structural steel

finish: flat black paint

WLL: 2000 lbs (909 kg)

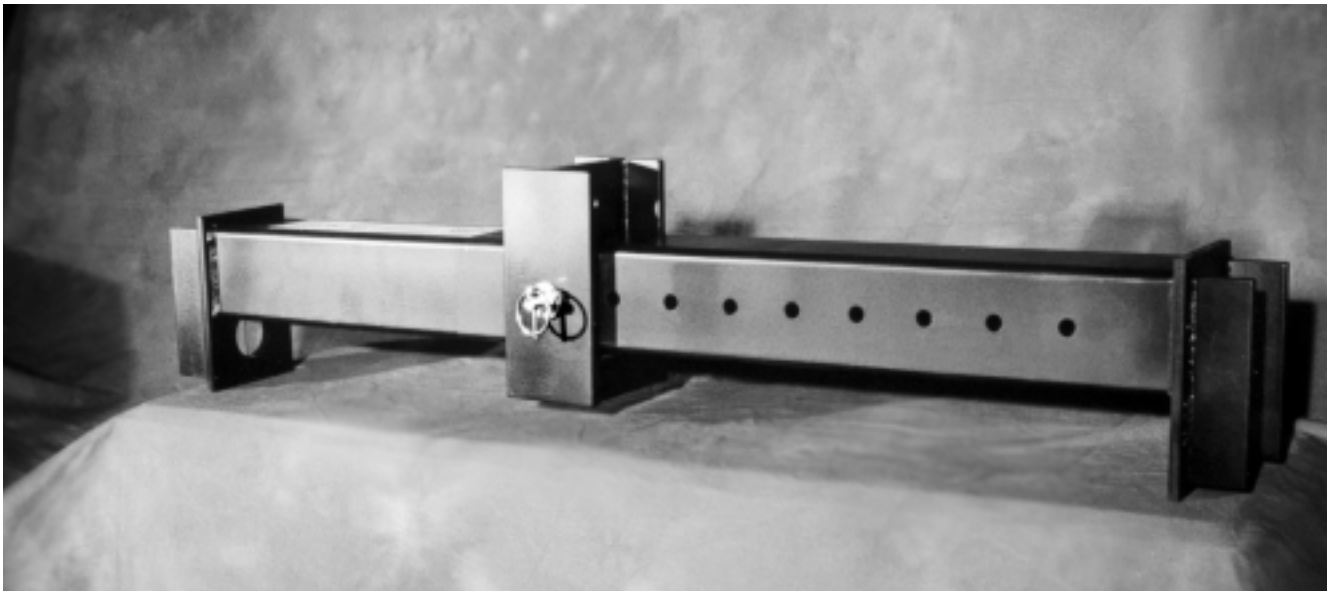
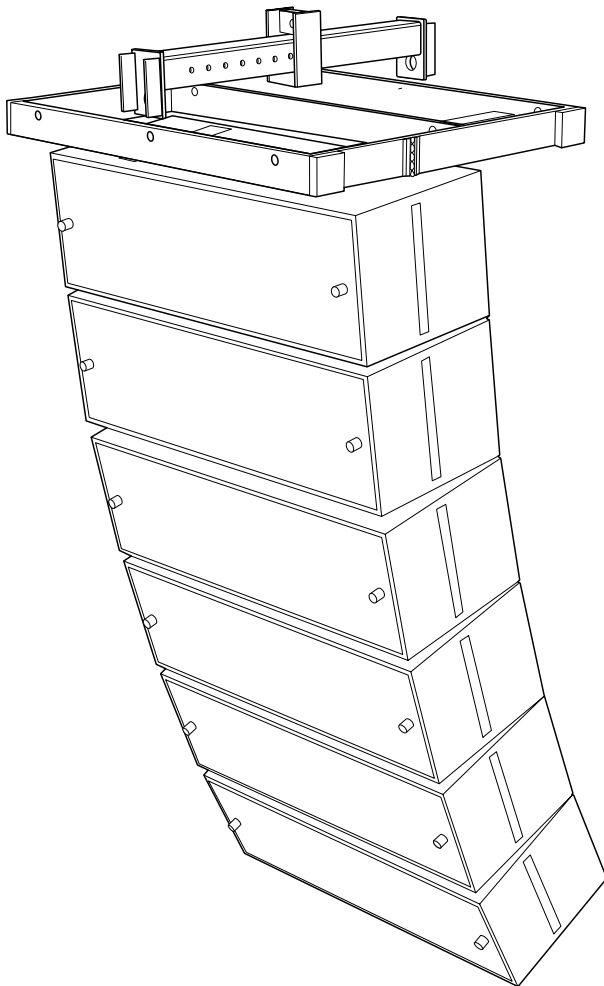
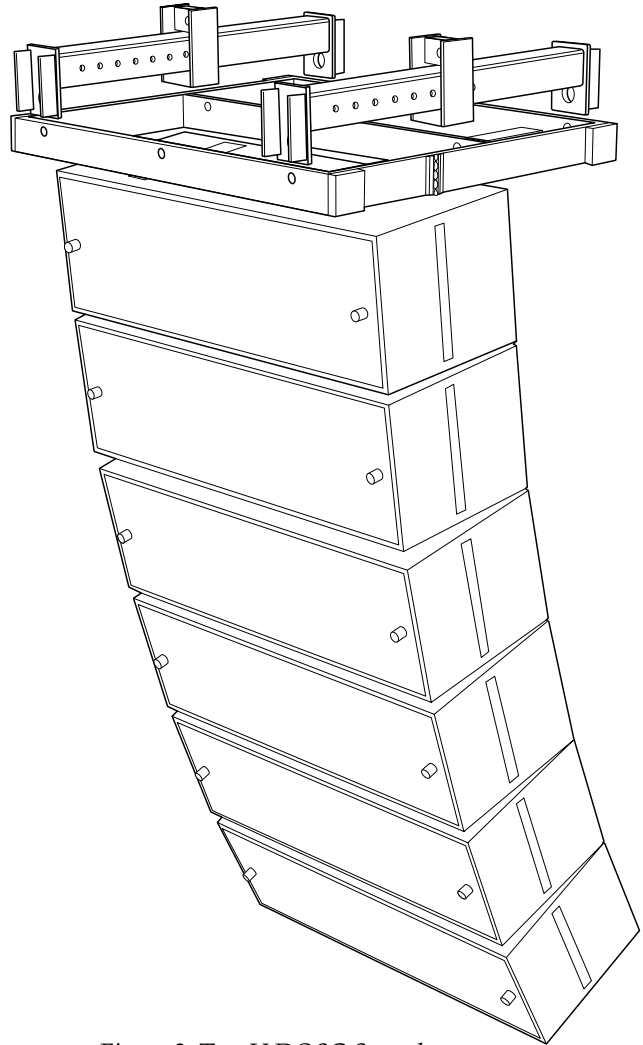

Figure 1. The V-DOSC Spreader



*Figure 2. One V-DOSC Spreader used to provide low head room single point support for a standard V-DOSC rig.*



*Figure 3. Two V-DOSC Spreaders used to provide low head room side by side support for a standard V-DOSC rig.*